

General Specifications

Model DA5
Distributor
(with Square Root Extractor)

JUXTA

GS 77J05A05-01E

General

The DA5, a nest-mounting type DCS-supported distributor with square root extractor, is used in combination with a two-wire transmitter to convert the differential pressure flow signal into a linearized signal proportional to the flow.

- With transmitter short-circuit protection and low-cut function
- On-site zero/span adjustment and I/O monitoring etc. can be performed from the host system or a handy terminal via the communication interface.
- Available for use with safety barriers.

Model and Suffix Codes

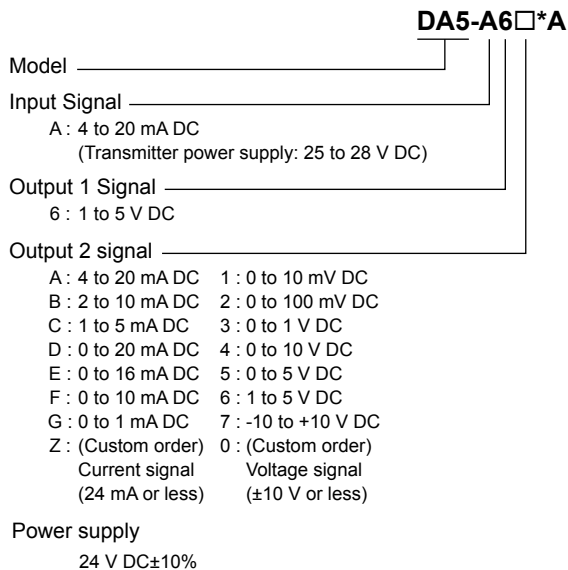

Ordering Information

Specify the following when ordering.

- Model and suffix codes: e.g. DA5-A6A*A
- Low cut point: e.g. 0.5%
 (If not specified, the low cut point is set to 0.6%.)

Input/Output Specifications

Input signal: 4 to 20 mA DC signal from two-wire transmitter

Input resistance: 250 Ω

Maximum allowable input: 40 mA DC

Transmitter power supply: 26.5±1.5 V DC
 (With a current limiting circuit to keep the current between 25 and 35 mA)

Allowable conductor resistance (RL):
 Up to [(20 – transmitter's minimum operating voltage) V/0.02 A] Ω

Input compensation:

$$Y = \left(\sqrt{\frac{X - (\text{input } 0 \% \text{ value})}{\text{input span}}} \right) \times (\text{output span}) + (\text{output } 0 \% \text{ value})$$
 X: Input value, Y: Output value

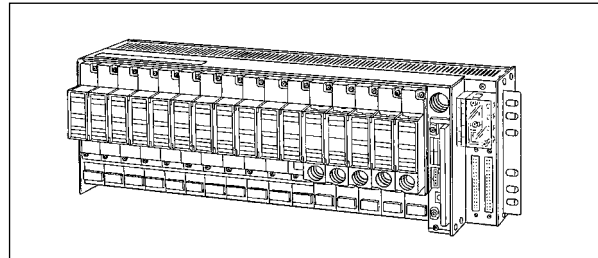

Lowcut point setting range: 0.3 to 100%

Output characteristic: Output for lowcut point or less is cramped with straight line proportional to input.

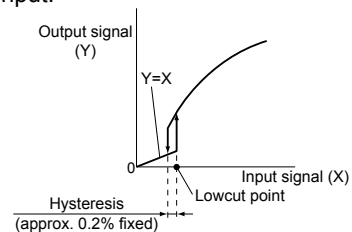

Output 1 signal: 1 to 5 V DC

Output 2 signal: DC current or DC voltage signal
 (In the case of DC current, only either from the front terminals 3-4 or from the connector can be output)

Allowable load resistance:

DC current output	Allowable load resistance	DC voltage output	Allowable load resistance
4 to 20 mA	750 Ω or less	0 to 10 mV	250 kΩ or more
2 to 10 mA	1500 Ω or less	0 to 100 mV	250 kΩ or more
1 to 5 mA	3000 Ω or less	0 to 1 V	2 kΩ or more
0 to 20 mA	750 Ω or less	0 to 10 V	10 kΩ or more
0 to 16 mA	900 Ω or less	0 to 5 V	2 kΩ or more
0 to 10 mA	1500 Ω or less	1 to 5 V	2 kΩ or more
0 to 1 mA	15 kΩ or less	-10 to +10 V	10 kΩ or more

Input adjustment: ±1% of span (Zero/Span)

Output adjustment: ±10% of span (Zero/Span)

Standard Performance

Accuracy rating:

Output 1: ±0.1% of span

Output 2: Relative error between output 1 and 2 is within ±0.2%.

Accuracy is not guaranteed for output level less than 0.5% of the span of a 0 to X mA output range type.

Response speed: 200 ms, 63% response (10 to 90%)

Insulation resistance: 100 MΩ or more at 500 V DC between input and output, output and power supply, and input and power supply.

Withstand voltage: 1500 V AC/min. between input and (output and power supply). 500 V AC/min. between output and power supply.

■ Environmental Conditions

Operating temperature range: 0 to 50°C
 Operating humidity range: 5 to 90% RH (no condensation)
 Power supply voltage: 24 V DC±10% (ripple content 5% p-p or less)
 Effect of power supply voltage fluctuations: ±0.1% of span or less for fluctuation within the operating range of power supply voltage specification.
 Effect of ambient temperature change: ±0.2% of span or less for a temperature change of 10°C.
 Current consumption: 24 V DC 110 mA (4 to 20 mA), 75 mA (1 to 5 V)

■ Mounting and Dimensions

Mounting method: Nest-mounting (Signals and power supply are connected through back board and connector)
 Connection method: Connection to M4 screw terminals of the exclusive nest
 External dimensions: 130.6(H)×23.6(W)×126(D) mm
 Weight: Approx. 120 g

■ Standard Accessories

Tag number label: 1

■ Custom Order Specifications

	Current signal	Voltage signal
Output range (DC)	0 to 24 mA	-10 to +10 V
Span (DC)	1 to 24 mA	10 mV to 20 V
Zero elevation	0 to 200%	-100 to +200%

■ Terminal Assignments

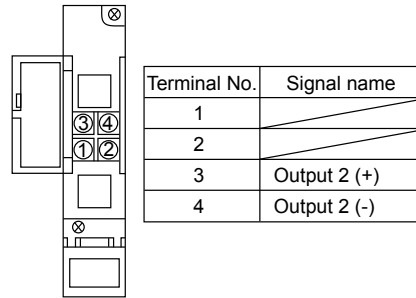

■ Block Diagram

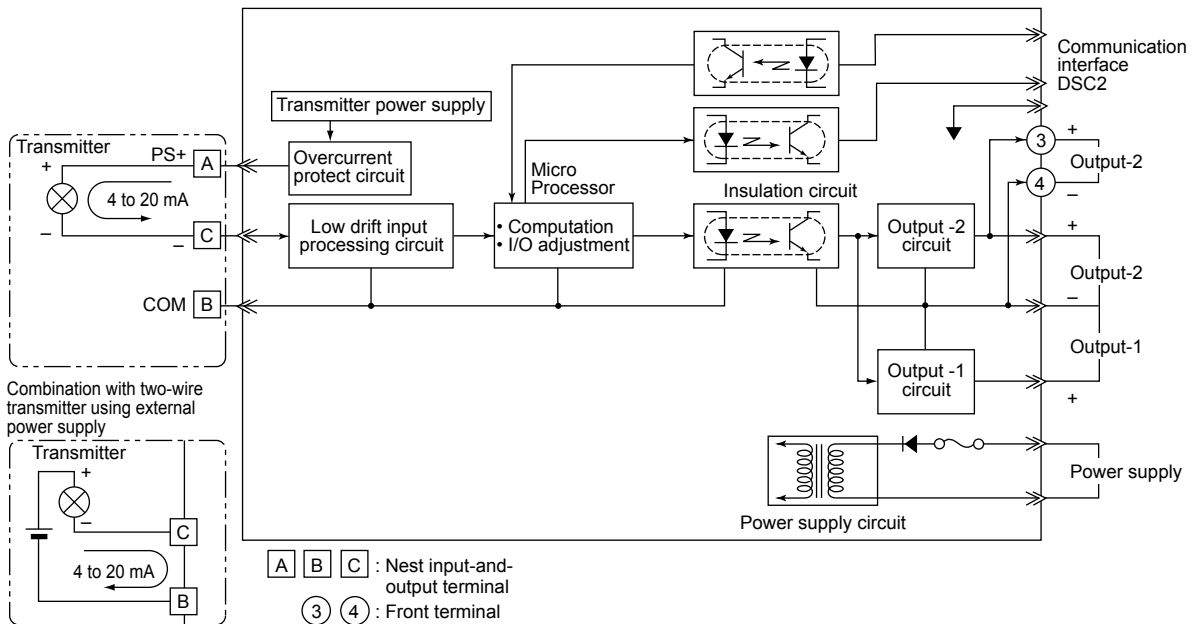

External Dimensions

